

MESA18-0146Y4
R134a
24 V DC
VARIABLE SPEED (1200-6000 rpm)



Brushless DC Variable Speed Compressor Technical Data Sheet

General Information

Compressor Part Number	MESA00004	1/4" (6.54 mm) ID Suction 3/16" (4.95 mm) ID Discharge
Compressor Drawing	DCMX43	
Controller	025F0361	
Controller Drawing	DGMX0089	
Wiring Diagram	DEMX0058	

Design

Number of Cylinders	2
Total Displacement	0.146 in ³ (2.4 cm ³)
Oil Quantity	50 cc
Oil Type	POE - 170 cSt
Weight	2.65 lb / 1.20 kg

Application Information

HIGH BACK PRESSURE (HBP)	
Evaporator Temperature Range	-13° F to 68° F (-25° C to 20° C)
Condenser Temperature Range	47.5° F to 162° F (8.6° C to 72° C)
LOW BACK PRESSURE (LBP)	
Evaporator Temperature Range	-40° F to 10° F (-40° C to 12.2° C)
Condenser Temperature Range	100° F to 140° F (37.8° C to 60° C)
Maximum Discharge Temperature	239° F (115° C)
Maximum Compression Ratio	13:1
Minimum Compressor Cooling	1 m/s airflow over compressor

Rating Condition

	HBP		LBP	
Condensing Temperature	130°F	(54.4°C)	130°F	(54.4°C)
Evaporating Temperature	45°F	(7.2°C)	-10°F	(-23.3°C)
Return Gas Temperature	95°F	(35.0°C)	90°F	(32.2°C)
Liquid Temperature	115°F	(46.1°C)	90°F	(32.2°C)
Ambient Temperature	95°F	(35.0°C)	90°F	(32.2°C)
Compressor Cooling	1 m/s air cooling			
Controller	025F0361			

Packaging Options

- Single Pack (add -SP suffix to part number when ordering)
- Pallet Pack (90 piece multiples) (add -FP suffix to part number when ordering)

MESA18-0146Y4



Compressor Dimensions

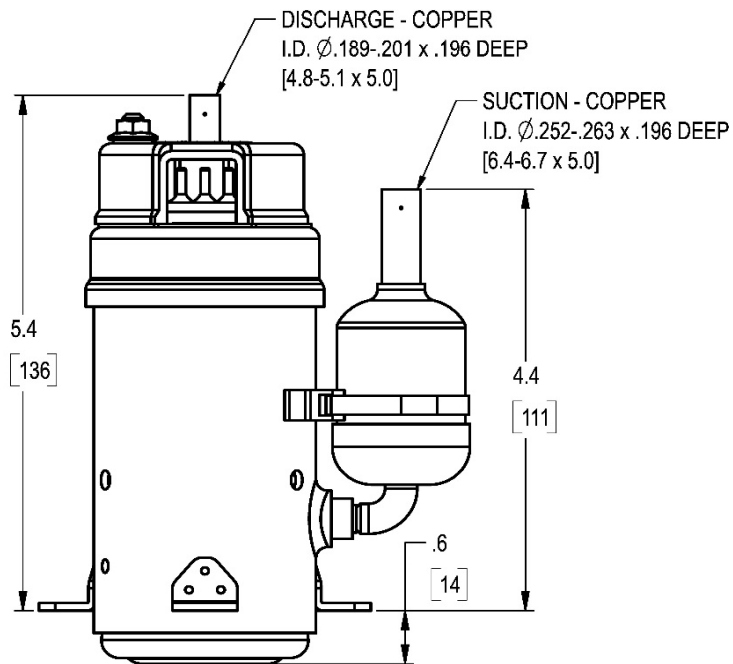
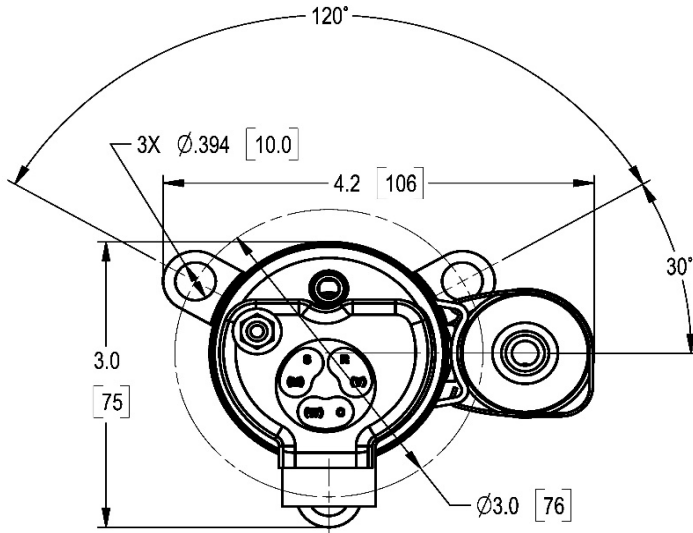

Controller Configuration

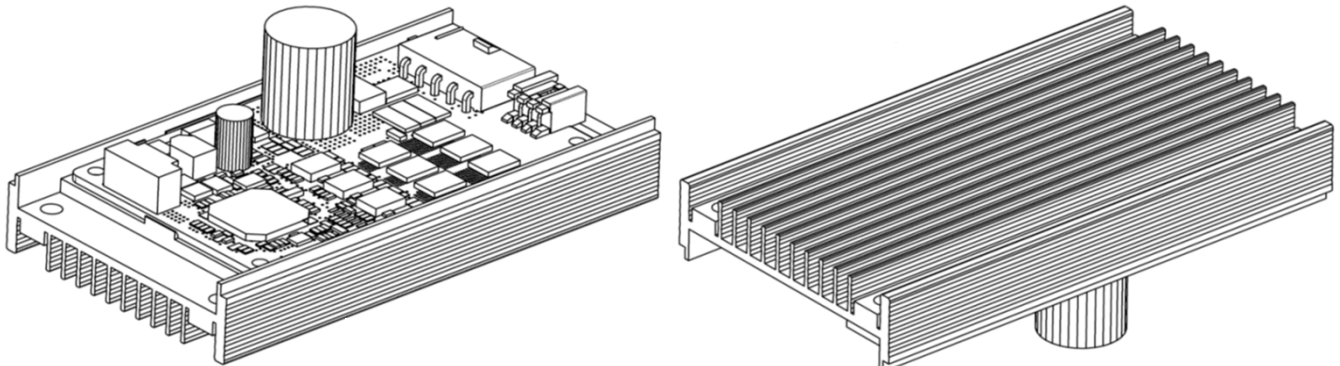

Cooling Capacity (24V) - ASHRAE HBP BTU/hr (Watt)

RPM	Evaporator Temperature													
	0°F	(-17.8°C)	10°F	(-12.2°C)	20°F	(-6.7°C)	30°F	(-1.1°C)	45°F	(7.2°C)	55°F	(12.8°C)	68°F	(20°C)
1200	95	(28)	134	(39)	180	(53)	236	(69)	342	(100)	432	(126)	573	(168)
2400	209	(61)	291	(85)	393	(115)	517	(151)	749	(220)	938	(275)	1229	(360)
3600	321	(94)	443	(130)	597	(175)	785	(230)	1138	(333)	1423	(417)	1857	(544)
4800	432	(127)	589	(173)	791	(232)	1040	(305)	1508	(442)	1885	(552)	2457	(720)
6000	541	(159)	730	(214)	976	(286)	1282	(376)	1858	(544)	2324	(681)	3030	(887)

Power Consumption (24V) - ASHRAE HBP Watt **Current (24V) - ASHRAE HBP** Amp

RPM	Evaporator Temperature								Evaporator Temperature							
	0°F	10°F	20°F	30°F	45°F	55°F	68°F	0°F	10°F	20°F	30°F	45°F	55°F	68°F		
1200	49	52	55	59	63	63	60	2.05	2.16	2.30	2.45	2.61	2.64	2.51		
2400	60	66	72	78	84	85	83	2.51	2.74	3.00	3.23	3.49	3.56	3.46		
3600	84	93	101	109	117	120	118	3.50	3.86	4.21	4.53	4.89	4.99	4.92		
4800	110	121	132	142	153	156	155	4.58	5.05	5.51	5.91	6.36	6.50	6.45		
6000	127	141	155	166	179	183	182	5.30	5.89	6.44	6.93	7.46	7.64	7.60		

Efficiency (24V) - ASHRAE HBP BTU/hr/W (W/W)

RPM	Evaporator Temperature													
	0°F	(-17.8°C)	10°F	(-12.2°C)	20°F	(-6.7°C)	30°F	(-1.1°C)	45°F	(7.2°C)	55°F	(12.8°C)	68°F	(20°C)
1200	1.94	(0.57)	2.59	(0.76)	3.26	(0.96)	4.01	(1.18)	5.46	(1.60)	6.82	(2.00)	9.53	(2.79)
2400	3.47	(1.01)	4.42	(1.29)	5.47	(1.60)	6.67	(1.95)	8.95	(2.62)	10.99	(3.22)	14.82	(4.34)
3600	3.82	(1.12)	4.78	(1.40)	5.90	(1.73)	7.22	(2.11)	9.70	(2.84)	11.88	(3.48)	15.74	(4.61)
4800	3.93	(1.15)	4.86	(1.42)	5.98	(1.75)	7.33	(2.15)	9.88	(2.89)	12.08	(3.54)	15.88	(4.65)
6000	4.26	(1.25)	5.16	(1.51)	6.31	(1.85)	7.71	(2.26)	10.38	(3.04)	12.68	(3.71)	16.61	(4.86)

* all points are at 35°C (95°F) ambient temperature, 35°C (95°F) suction, 8.33°C (15°F) subcooling, 54.4°C (130°F) condenser

Performance Coefficients (24V) - ASHRAE HBP

Coefficient	Capacity (BTU/Hr)	Power (Watts)	Current (Amperes)	Mass Flow (Lbs/Hr)
C1	6.271397E+03	-6.860510E+02	-2.858546E+01	
C2	2.186900E-01	-5.386318E-02	-2.244299E-03	
C3	-3.338943E-06	1.195254E-05	4.980224E-07	
C4	-3.258251E-11	-1.028112E-09	-4.283800E-11	
C5	-2.087500E+01	-1.601070E+00	-6.671127E-02	
C6	-2.892860E-02	7.642546E-03	3.184394E-04	
C7	3.638879E-04	-1.223623E-04	-5.098429E-06	
C8	-1.479660E+02	1.775464E+01	7.397768E-01	
C9	1.153921E+00	-1.408738E-01	-5.869742E-03	
C10	-2.984253E-03	3.732780E-04	1.555325E-05	
C11	-5.104540E-05	5.230555E-06	2.179398E-07	
C12	-4.155358E-11	-6.171432E-11	-2.571430E-12	
C13	-2.184707E-07	2.611580E-08	1.088158E-09	
C14	1.356667E-07	-8.732477E-09	-3.638532E-10	
C15	7.899476E-03	-2.598589E-04	-1.082746E-05	
C16	-8.483579E-04	3.290809E-04	1.371170E-05	
C17	3.144961E-01	2.154489E-02	8.977038E-04	
C18	-1.282377E-07	6.033323E-09	2.513885E-10	
C19	8.081360E-05	-5.201204E-06	-2.167168E-07	
C20	2.436299E-08	-1.062441E-09	-4.426839E-11	
C21	-7.548974E-07	-6.997072E-07	-2.915447E-08	
C22	-6.274332E-05	1.751756E-05	7.298983E-07	
C23	-1.212318E-03	-7.826808E-05	-3.261170E-06	

TO BE DETERMINED

Performance Equation

$$Y = C_1 + C_2 X_1 + C_3 X_1^2 + C_4 X_1^3 + C_5 X_2 + C_6 X_2^2 + C_7 X_2^3 + C_8 X_3 + C_9 X_3^2 + C_{10} X_3^3 + C_{11} X_1 X_2 X_3 + C_{12} X_1^2 X_2 X_3 + C_{13} X_1 X_2^2 X_3 + C_{14} X_1 X_2 X_3^2 + C_{15} X_1 X_2 X_3 + C_{16} X_1 X_3 + C_{17} X_2 X_3 + C_{18} X_1^2 X_2 + C_{19} X_1 X_2^2 + C_{20} X_1^2 X_3 + C_{21} X_1 X_3^2 + C_{22} X_2^2 X_3 + C_{23} X_2 X_3^2$$

X₁ = RPM
 X₂ = E_t (°F)
 X₃ = C_t (°F)

Cooling Capacity (24V) - ASHRAE LBP BTU/hr (Watt)

RPM	Evaporator Temperature												
	-40°F (-40°C)	-30°F (-34.4°C)	-20°F (-28.9°C)	-10°F (-23.3°C)	0°F (-17.8°C)	5°F (-15°C)	10°F (-12.2°C)						
1200					72	(21)	113	(33)	134	(39)	155	(45)	
2400				109	(32)	184	(54)	261	(76)	301	(88)	343	(100)
3600		62	(18)	172	(50)	288	(84)	411	(120)	476	(139)	543	(159)
4800		82	(24)	240	(70)	407	(119)	585	(171)	679	(199)	777	(227)
6000		118	(34)	332	(97)	560	(164)	803	(235)	932	(273)	1064	(312)

Power Consumption (24V) - ASHRAE LBP Watt **Current (24V) - ASHRAE LBP** Amp

RPM	Evaporator Temperature							Evaporator Temperature						
	-40°F	-30°F	-20°F	-10°F	0°F	5°F	10°F	-40°F	-30°F	-20°F	-10°F	0°F	5°F	10°F
1200				39	43	45	47				1.63	1.80	1.89	1.97
2400			49	56	62	65	68			2.06	2.32	2.59	2.72	2.85
3600		60	68	77	86	91	95		2.50	2.85	3.23	3.60	3.78	3.95
4800		79	90	102	114	119	125		3.28	3.76	4.26	4.75	4.98	5.20
6000		98	113	128	142	149	155		4.07	4.69	5.32	5.92	6.21	6.48

Efficiency (24V) - ASHRAE LBP BTU/hr/W (W/W)

RPM	Evaporator Temperature												
	-40°F (-40°C)	-30°F (-34.4°C)	-20°F (-28.9°C)	-10°F (-23.3°C)	0°F (-17.8°C)	5°F (-15°C)	10°F (-12.2°C)						
1200					1.83	(0.54)	2.62	(0.77)	2.95	(0.86)	3.27	(0.96)	
2400				2.21	(0.65)	3.30	(0.97)	4.20	(1.23)	4.61	(1.35)	5.02	(1.47)
3600		1.03	(0.30)	2.52	(0.74)	3.72	(1.09)	4.76	(1.39)	5.24	(1.54)	5.72	(1.68)
4800		1.05	(0.31)	2.65	(0.78)	3.98	(1.16)	5.14	(1.50)	5.68	(1.66)	6.23	(1.82)
6000		1.21	(0.35)	2.95	(0.86)	4.39	(1.28)	5.65	(1.66)	6.25	(1.83)	6.85	(2.00)

* all points are at 32.2°C (90°F) ambient temperature, 32.2°C (90°F) suction, 22.2°C (40°F) subcooling, 54.4°C (130°F) condenser

Performance Coefficients (24V) - ASHRAE LBP

Coefficient	Capacity (BTU/Hr)	Power (Watts)	Current (Amperes)	Mass Flow (Lbs/Hr)
C1	2.239300E+03	-7.637202E+02	-3.182167E+01	
C2	-1.351394E-01	2.565925E-02	1.069135E-03	
C3	-3.561884E-06	2.447959E-06	1.019983E-07	
C4	2.033125E-09	-2.285633E-10	-9.523469E-12	
C5	6.069996E+00	-2.677800E+00	-1.115750E-01	
C6	9.772883E-02	-8.966068E-03	-3.735862E-04	
C7	2.998851E-04	-8.726230E-05	-3.635929E-06	
C8	-5.444230E+01	1.949983E+01	8.124928E-01	
C9	4.280490E-01	-1.593807E-01	-6.640862E-03	
C10	-1.114873E-03	4.344135E-04	1.810056E-05	
C11	-1.475922E-05	4.434025E-06	1.847510E-07	
C12	1.797947E-09	5.855083E-12	2.439618E-13	
C13	8.790746E-07	-3.985849E-08	-1.660770E-09	
C14	8.732098E-08	-1.003811E-08	-4.182546E-10	
C15	2.389783E-03	-2.435265E-04	-1.014694E-05	
C16	5.267594E-03	-4.811607E-04	-2.004836E-05	
C17	-9.518923E-02	4.811285E-02	2.004702E-03	
C18	1.055251E-07	4.794069E-09	1.997529E-10	
C19	-9.669559E-05	4.067568E-06	1.694820E-07	
C20	-7.859538E-08	8.456047E-09	3.523353E-10	
C21	-2.351035E-05	2.494970E-06	1.039571E-07	
C22	-8.936974E-04	7.954257E-05	3.314274E-06	
C23	4.502883E-04	-1.985828E-04	-8.274283E-06	

TO BE DETERMINED

Performance Equation

$$Y = C_1 + C_2 X_1 + C_3 X_1^2 + C_4 X_1^3 + C_5 X_2 + C_6 X_2^2 + C_7 X_2^3 + C_8 X_3 + C_9 X_3^2 + C_{10} X_3^3 + C_{11} X_1 X_2 X_3 + C_{12} X_1^2 X_2 X_3 + C_{13} X_1 X_2^2 X_3 + C_{14} X_1 X_2 X_3^2 + C_{15} X_1 X_2 X_3 + C_{16} X_1 X_3 + C_{17} X_2 X_3 + C_{18} X_1^2 X_2 + C_{19} X_1 X_2^2 + C_{20} X_1^2 X_3 + C_{21} X_1 X_3^2 + C_{22} X_2^2 X_3 + C_{23} X_2 X_3^2$$

X₁ = RPM
 X₂ = E_t (°F)
 X₃ = C_t (°F)